



Thin Film Technology Corp.

Product Family: Automotive Thick Film Chip Resistors

Part Number Series: TFA Series



	<p>Construction:</p> <ul style="list-style-type: none"> Alumina substrate Highly reliable and stable thick film resistive element Wrap around electrodes RoHS compliant and Pb free 100% matte tin over Ni terminations 	<p>Features:</p> <ul style="list-style-type: none"> 0402, 0603, 0805, 1206, 1210, 1812, 2010, and 2512 English case sizes Resistances from 1Ω~10MΩ & Jumper available Tolerances down to ±0.1% TCR's down to ±100ppm/°C AEC-Q200 Qualified
----------------------------------------------------------------------------------	-----------------------------------------------------------------------------------------------------------------------------------------------------------------------------------------------------------------------------------------------------------------------------------	----------------------------------------------------------------------------------------------------------------------------------------------------------------------------------------------------------------------------------------------------------------------------------------------------------

Description:

These precision thick film chip resistors are automotive grade AEC-Q200 qualified making them an excellent choice for automotive applications, telecom applications, and EDP computer applications. High volume manufacturing allows for lower costs for the customer.

Product Dimensions:

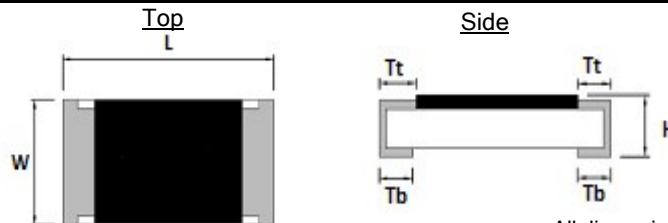

All dimensions shown in inches, mm in parentheses.

Dimension (Metric)	L	W	H	Tt	Tb
TFA0402 (1005)	0.039 ±0.002 (1.00 ±0.05)	0.019 ±0.002 (0.50 ±0.05)	0.012 ±0.002 (0.30 ±0.05)	0.006 ±0.004 (0.15 ±0.10)	0.008 ±0.004 (0.20 ±0.10)
TFA0603 (1608)	0.063 ±0.004 (1.60 ±0.10)	0.031 ±0.004 (0.80 ±0.10)	0.016 ±0.004 (0.40 ±0.10)	0.012 ±0.008 (0.30 ±0.20)	0.012 ±0.004 (0.30 ±0.10)
TFA0805 (2012)	0.079 ±0.004 (2.00 ±0.10)	0.049 ±0.004 (1.25 ±0.10)	0.019 ±0.006 (0.50 ±0.15)	0.012 ±0.006 (0.30 ±0.15)	0.016 ±0.006 (0.40 ±0.15)
TFA1206 (3216)	0.120 ±0.004 (3.05 ±0.10)	0.063 ±0.004 (1.60 ±0.10)	0.022 ±0.006 (0.55 ±0.15)	0.016 ±0.008 (0.40 ±0.20)	0.019 ±0.008 (0.50 ±0.20)
TFA1210 (3226)	0.120 ±0.004 (3.05 ±0.10)	0.098 ±0.006 (2.50 ±0.15)	0.022 ±0.006 (0.55 ±0.15)	0.019 ±0.008 (0.50 ±0.20)	0.019 ±0.008 (0.50 ±0.20)
TFA1812 (3248)	0.177 ±0.004 (4.50 ±0.10)	0.122 ±0.006 (3.10 ±0.15)	0.022 ±0.002 (0.55 ±0.05)	0.022 ±0.008 (0.55 ±0.20)	0.028 ±0.008 (0.70 ±0.20)
TFA2010 (5025)	0.197 ±0.008 (5.00 ±0.20)	0.098 ±0.006 (2.50 ±0.15)	0.022 ±0.004 (0.55 ±0.10)	0.024 ±0.008 (0.60 ±0.20)	0.024 ±0.008 (0.60 ±0.20)
TFA2512 (6432)	0.248 ±0.008 (6.30 ±0.20)	0.126 ±0.006 (3.20 ±0.15)	0.022 ±0.004 (0.55 ±0.10)	0.024 ±0.008 (0.60 ±0.20)	0.024 ±0.008 (0.60 ±0.20)

Part Numbering: Ex: TFA0603R1002F-T5

Series Name	English Size (Metric Size)	Temp. Coefficient of Resistance (TCR)	Resistance Value	Resistance Tolerance	T&R Packaging Quantity
TFA	0402 (1005) 0603 (1608) 0805 (2012) 1206 (3216) 1210 (3226) 1812 (3248) 2010 (5025) 2512 (6432)	R = ±100ppm/°C W = see electrical table	4 digits with the first 3 being significant. The last digit specifies the number of zeros. "R" denotes decimal position as necessary Jumper = JUMP	B = ±0.1% D = ±0.5% F = ±1.0%* G = ±2.0% J = ±5.0%	-T4 = 4,000 pcs/reel -T5 = 5,000 pcs/reel -T10 = 10,000 pcs/reel (see electrical table)

* Note: Use "F" resistance tolerance code for all Jumper products indicating max resistance of 50mΩ.

Electrical Specifications:

Type	TFA0402			TFA0603			TFA0805			TFA1206		
Metric	1005			1608			2012			3216		
Power Rating	1/16W			1/10W			1/8W			1/4W		
Resistance Range (Ω)	1~9.99	10~1M	10~10M	1~9.99	10~1M	10~10M	1~9.99	10~1M	10~10M	1~9.99	10~1M	10~10M
Resistance Tolerance % (code)	± 1.0 (F) ± 2.0 (G) ± 5.0 (J)	± 0.1 (B) ± 0.5 (D)	± 1.0 (F) ± 2.0 (G) ± 5.0 (J)	± 1.0 (F) ± 2.0 (G) ± 5.0 (J)	± 0.1 (B) ± 0.5 (D)	± 1.0 (F) ± 2.0 (G) ± 5.0 (J)	± 1.0 (F) ± 2.0 (G) ± 5.0 (J)	± 0.1 (B) ± 0.5 (D)	± 1.0 (F) ± 2.0 (G) ± 5.0 (J)	± 1.0 (F) ± 2.0 (G) ± 5.0 (J)	± 0.1 (B) ± 0.5 (D)	± 1.0 (F) ± 2.0 (G) ± 5.0 (J)
TCR ppm/ $^{\circ}$ C (code)	± 400 (W)	± 100 (R)	± 400 (W)	± 100 (R)	± 400 (W)	± 100 (R)	± 400 (W)	± 100 (R)	± 400 (W)	± 100 (R)	± 400 (W)	± 100 (R)
Max Operating Voltage	50V			75V			150V			200V		
Max Overload Voltage	100V			100V			300V			400V		
Operating Temp. Range	-55 $^{\circ}$ C~+155 $^{\circ}$ C											
Packaging	10,000 pcs/reel (-T10)			5,000 pcs/reel (-T5)								

Type	TFA1210			TFA1812			TFA2010			TFA2512		
Metric	3226			3248			5025			6432		
Power Rating	1/2W			3/4W			3/4W			1W		
Resistance Range (Ω)	1~9.99	10~1M	10~10M	1~9.99	10~1M	10~10M	1~9.99	10~1M	10~10M	1~9.99	10~1M	10~10M
Resistance Tolerance % (code)	± 1.0 (F) ± 2.0 (G) ± 5.0 (J)	± 0.1 (B) ± 0.5 (D)	± 1.0 (F) ± 2.0 (G) ± 5.0 (J)	± 1.0 (F) ± 2.0 (G) ± 5.0 (J)	± 0.1 (B) ± 0.5 (D)	± 1.0 (F) ± 2.0 (G) ± 5.0 (J)	± 1.0 (F) ± 2.0 (G) ± 5.0 (J)	± 0.1 (B) ± 0.5 (D)	± 1.0 (F) ± 2.0 (G) ± 5.0 (J)	± 1.0 (F) ± 2.0 (G) ± 5.0 (J)	± 0.1 (B) ± 0.5 (D)	± 1.0 (F) ± 2.0 (G) ± 5.0 (J)
TCR ppm/ $^{\circ}$ C (code)	± 400 (W)	± 100 (R)	± 400 (W)	± 100 (R)	± 400 (W)	± 100 (R)	± 400 (W)	± 100 (R)	± 400 (W)	± 100 (R)	± 400 (W)	± 100 (R)
Max Operating Voltage	200V			200V			200V			200V		
Max Overload Voltage	400V			400V			400V			400V		
Operating Temp. Range	-55 $^{\circ}$ C~+155 $^{\circ}$ C											
Packaging (code)	5,000 pcs/reel (-T5)			4,000 pcs/reel (-T4)								

Conditions for Jumper:

Type	TFA0402	TFA0603	TFA0805	TFA1206	TFA1210	TFA1812	TFA2010	TFA2512
Resistance	Max 50m Ω							
Rated Current	1A				2A			

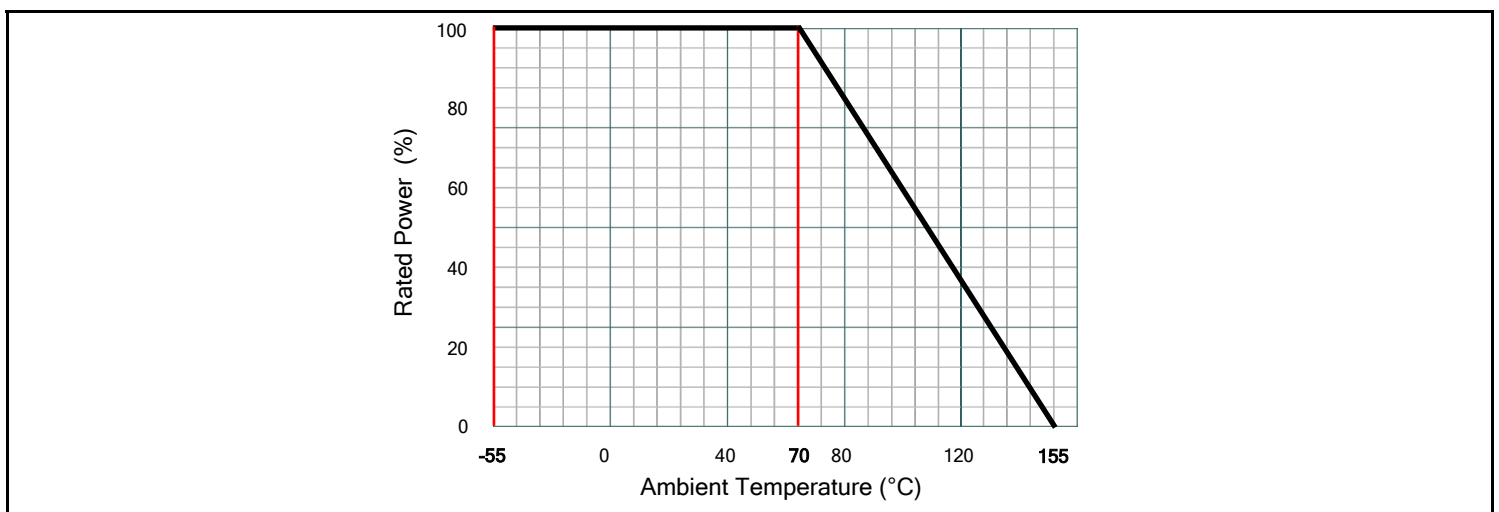
Power Derating Curve:

AEC-Q200 Test Requirements (Table 7):

AEC Test #	Test	Requirements	Specifications
3	High Temp. Exposure (Storage) MIL-STD-202 Method 108	Test temperature: 125 ±3°C Test period: 1,000 hours No electrical load	±1.0%
4	Temp. Cycling (Thermal Shock) JESD22 Method JA-104	Repeat 1,000 cycles as follows: -55 ±3°C for 30 minutes 125 ±3°C for 30 minutes Transition time of 1 minute maximum	±1.0%
7	Biased Humidity MIL-STD-202 Method 103	Test conditions: 85°C and 85% RH 10% of rated power Test period: 1,000 hours	±1.0%
8	Load Life (Operational Life) MIL-STD-202 Method 108	Test temperature: 125 ±3°C Applied voltage: rated power (derated power will be required if temp exceeds the derating point of the part) Test period: 1,000 hours	±1.0%
12	Resistance to Solvents MIL-STD-202 Method 215	3 minute soak 2-3 ounce force 10 strokes/repetition 3 repetitions	±1.0%
13	Mechanical Shock MIL-STD-202 Method 213	Force: 100G peak Test duration: 6 milliseconds Half-sine waveform Velocity: 12.3ft/sec.	±1.0%
14	Vibration MIL-STD-202 Method 204	Frequency: 10-2,000Hz Acceleration: 5G Test duration: 20 minutes, 12 cycles	±1.0%
15	Resistance to Soldering Heat MIL-STD-202 Method 210	Condition B (Solder dip, no pre-heat) 260 ±5°C	±1.0%
17	ESD AEC-Q200-002	HBM, 100pF, 1.5kΩ Repetition: 5 times	±1.0%
18	Solderability J-STD-002	Non-activated flux dip: 5-10 seconds SAC solder dip: 2 ±0.5 seconds at 245 ±5°C	>95% covered
20	Flammability UL-94	V-0 or V-1 are acceptable Electrical test not required	UL-94
21	Board Flex AEC-Q200-005	90mm span between fulcrums 2mm bend 60 seconds minimum holding time	±1.0%
22	Terminal Strength (SMD) AEC-Q200-006	Force of 17.7N 60 seconds	±1.0%
24	Flame Retardance AEC-Q200-001	Mounted parts subjected to voltages from 9.0 to 32.0 VDC (current clamped up to 500A) in 1.0 VDC increments. Voltage applied for 1 hour minimum or until failure occurs.	AEC-Q200-001

Paper Tape Dimensions:

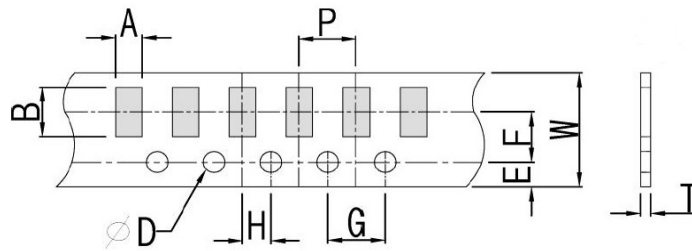

All dimensions in mm.

Size	A	B	W	E	F	G	H	T	ØD	P
0402	0.70 ±0.10	1.20 ±0.10	8.00 ±0.20	1.75 ±0.10	3.50 ±0.05	4.00 ±0.10	2.00 ±0.05	0.45 ±0.10	1.50 +0.10/-0	2.00 ±0.10
0603	1.05 ±0.20	1.80 ±0.20	8.00 ±0.20	1.75 ±0.10	3.50 ±0.05	4.00 ±0.10	2.00 ±0.05	0.60 ±0.10	1.50 +0.10/-0	4.00 ±0.10
0805	1.55 ±0.20	2.30 ±0.20	8.00 ±0.20	1.75 ±0.10	3.50 ±0.05	4.00 ±0.10	2.00 ±0.05	0.75 ±0.10	1.50 +0.10/-0	4.00 ±0.10
1206	1.90 ±0.20	3.50 ±0.20	8.00 ±0.20	1.75 ±0.10	3.50 ±0.05	4.00 ±0.10	2.00 ±0.05	0.75 ±0.10	1.50 +0.10/-0	4.00 ±0.10
1210	2.85 ±0.20	3.50 ±0.20	8.00 ±0.20	1.75 ±0.10	3.50 ±0.05	4.00 ±0.10	2.00 ±0.05	0.75 ±0.10	1.50 +0.10/-0	4.00 ±0.10

Plastic Tape Dimensions:

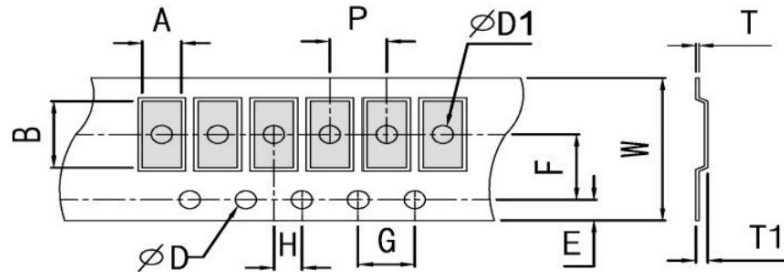

All dimensions in mm.

Size	A	B	W	E	F	G	H	T	ØD1	ØD	T1	P
1812	3.30 ±0.20	4.60 ±0.20	12.0 ±0.10	1.75 ±0.10	5.50 ±0.05	4.00 ±0.10	2.00 ±0.05	0.23 ±0.10	1.50 ±0.10	1.50 +0.10/-0	0.85 ±0.15	4.00 ±0.10
2010	2.80 ±0.20	5.60 ±0.20	12.0 ±0.10	1.75 ±0.10	5.50 ±0.05	4.00 ±0.10	2.00 ±0.05	0.23 ±0.10	1.50 ±0.10	1.50 +0.10/-0	0.85 ±0.15	4.00 ±0.10
2512	3.40 ±0.20	6.70 ±0.20	12.0 ±0.10	1.75 ±0.10	5.50 ±0.05	4.00 ±0.10	2.00 ±0.05	0.23 ±0.10	1.50 ±0.10	1.50 +0.10/-0	0.85 ±0.15	4.00 ±0.10

Reel Dimensions:

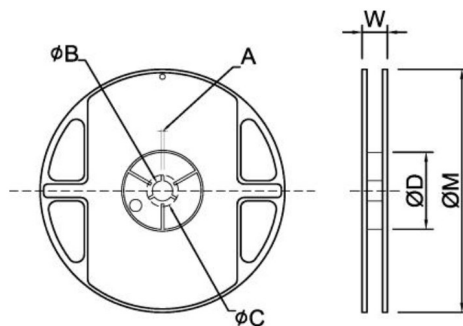

All dimensions in mm.

Size	Quantity	A	ØB	ØC	ØD	W	ØM
0402	10,000 pcs/reel	2.00 ±0.50	13.5 ±1.00	21.0 ±1.00	60.0 ±1.00	11.5 ±2.00	178 ±2.00
0603, 0805, 1206, 1210	5,000 pcs/reel	2.00 ±0.50	13.5 ±1.00	21.0 ±1.00	60.0 ±1.00	11.5 ±2.00	178 ±2.00
1812, 2010, 2512	4,000 pcs/reel	2.00 ±0.50	13.5 ±1.00	21.0 ±1.00	60.0 ±1.00	16.0 ±2.00	178 ±2.00

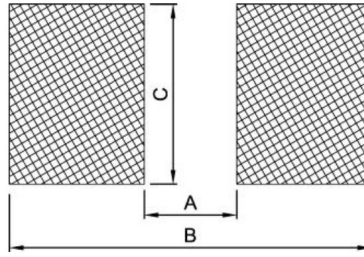
Recommended Land Pattern:

All dimensions in mm.

Size	0402	0603	0805	1206	1210	1812	2010	2512
A	0.60	0.80	1.30	2.20	2.00	3.11	3.80	4.90
B	1.60	2.40	2.90	4.20	4.40	5.91	6.60	8.10
C	0.70	1.00	1.40	1.70	2.70	3.00	2.70	3.40

Marking Information:

0402: no marking



0603: 3 digits code



0805~2512: 3 digits code (5%)



0805~2512: 4 digits code

Standard E96 Values and 0603 Resistance Codes

R-Value	100	102	105	107	110	113	115	118	121	124	127	130	133	137	140	143	147	150	154	158	162	165	169	174
Code	1	2	3	4	5	6	7	8	9	10	11	12	13	14	15	16	17	18	19	20	21	22	23	24
R-Value	178	182	187	191	196	200	205	210	215	221	226	232	237	243	249	255	261	267	274	280	287	294	301	309
Code	25	26	27	28	29	30	31	32	33	34	35	36	37	38	39	40	41	42	43	44	45	46	47	48
R-Value	316	324	332	340	348	357	365	374	383	392	402	412	422	432	442	453	464	475	487	499	511	523	536	549
Code	49	50	51	52	53	54	55	56	57	58	59	60	61	62	63	64	65	66	67	68	69	70	71	72
R-Value	562	576	590	604	619	634	649	665	681	698	715	732	750	768	787	806	825	845	866	887	909	931	953	976
Code	73	74	75	76	77	78	79	80	81	82	83	84	85	86	87	88	89	90	91	92	93	94	95	96

E96 Multiplier Code

Code	A	B	C	D	E	F	G	H	X	Y
Multiplier	10^0	10^1	10^2	10^3	10^4	10^5	10^6	10^7	10^{-1}	10^{-2}

Examples of 0603 Resistance Codes for E96 Values ($\pm 1\%$)

R-Value	4.99 Ω	33.2 Ω	475 Ω	2.21K Ω	10.2K Ω	604K Ω
Code	68Y	51X	66A	34B	02C	76C

Examples of 0603~2512: 3 digits code for E24 values ($\pm 5\%$)

R-Value	4.7 Ω	33 Ω	470 Ω	5.6K Ω	62K Ω	680K Ω
Code	4R7	330	471	562	623	684

Examples of 0805~2512: 4 digits code for type

R-Value	5.6 Ω	10 Ω	22.6 Ω	100 Ω	1.1K Ω	10K Ω	332K Ω	1M Ω
Code	5R60	10R0	22R6	1000	1101	1002	3323	1004

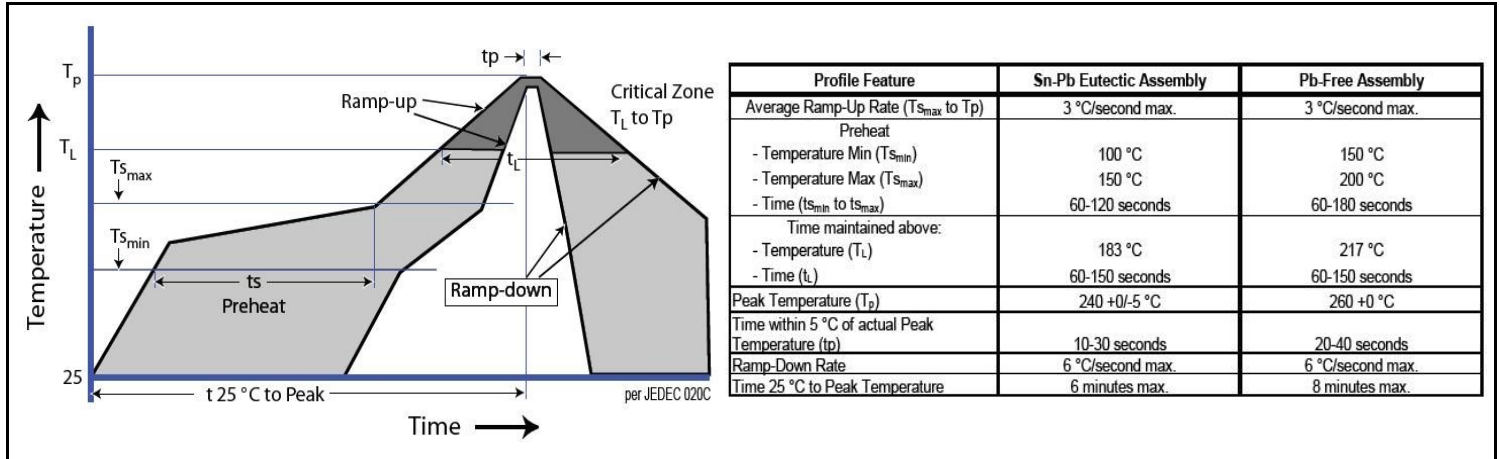
Soldering Profile:**Storage Conditions:****Environment Conditions:**

Products should be stored under the following environment conditions.

- Temperature: +5 to +35°C
- Humidity: 45 to 85% relative humidity
- Do not keep products in environments where they may be subject to particulate contamination or harmful gases such as sulfuric acid or hydrogen chloride as it may cause oxidization on electrodes, resulting in poor solderability.
- Products should be stored in a space that does not expose it to high temperatures, vibration, or direct sunlight.
- Products should be stored in the original airtight packaging until use.